

营口新东耐火材料有限公司
YINGKOU NEW EAST REFRACTORIES CO.,LTD.



新 东 耐 火

NAQ

质量管理体系认证证书

编号: 01000Q1000000

证 书 号

营口新东耐火材料有限公司

辽宁省营口市南楼经济开发区观马山工业园 邮编: 115103

质量管理体系符合

GB/T 19001-2000 idt ISO 9001:2000

该体系覆盖范围为

镁碳砖、铝镁碳砖耐火材料系列产品的生产

涉及本证书的范围和 GB/T 19001-2000 idt ISO 9001:2000 的要求, 可通过向该组织咨询得到进一步的详述。

本证书有效期自 2006 年 08 月 10 日至 2009 年 08 月 09 日

东北认证有限公司

总经理 (签名):

日期: 2006.8.10

国家认证注册号: CNAB 0100

NAQ

CERTIFICATE OF CONFORMITY OF QUALITY MANAGEMENT SYSTEM

NO. 01000Q1000000

This is to certify that the quality management system of

YINGKOU NEW EAST REFRACTORIES CO., LTD

QINWANGSHI INDUSTRIAL PARK, NALUO DEVELOPMENT ZONE, YINGKOU CITY, LIAONING PROVINCE.

POSTCODE: 115103

is in conformity with

GB/T 19001-2000 idt ISO 9001:2000 Standard

The scope of activities covered by this certificate are defined below:

PRODUCTION OF A SERIES OF REFRACTORIES PRODUCTS FOR MgO-C BRICKS AND AlMgC BRICKS

Further clarifications regarding the scope of this certificate and the applicability of GB/T 19001-2000 idt ISO 9001:2000 requirements may be obtained by consulting the organization.

Term of validity of this certificate from AUG 10, 2006 to AUG 09, 2009 inclusive

Northeast Audit Co., Ltd.

General Manager

Date: 2006.8.10

Registration Number: CNAB 0100



REFRACTORIES

勇创新 高 与时俱进 跨越发展 屹域东 产

新东耐火创造和谐!

全国工业产品生产许可证

营口新东耐火材料有限公司

经审查, 你单位生产的下列产品符合取得生产许可证条件, 特发此证。

产品名称: 耐火材料(明细见副本)

住 所: 辽宁省大石桥市南楼经济开放区观马山工业园区

生产地址: 辽宁省大石桥市南楼经济开放区观马山工业园区

证书编号: XK05-206-00176

有效期至: 2011年08月06日

有效期届满6个月前, 企业应当提出换证申请。

2006 年 08 月 07 日





ZZS312250振动筛 Vibratory Screen



自动配料控制室 Auto Scale Control Room



FCB4/1侧插布袋除尘器 Dust Collector



B400-13.5m皮带机与料仓 Feeder

PCL-1000 电子配料称 Scale Car



NHG-600L 高速混炼机 High Speed Mixer



成品与干燥车 Finished Product and Drier



NEW EAST REFRACTORIES



JA69-1600复合式压砖机 1600T Vacuum Friction Press



J93G-1000吨磨擦压力机 1000T Friction Press
J93G-630吨磨擦压力机 630T Friction Press



真空干燥器 Vacuum Specification



常温耐压测试机 Cold Crushing Strength Test Machine



抗 渣 炉 Rotary corrosion Tester



天 平 Scale





精良的检测仪器，

严谨的科学态度，

踏实的工作作风，

-----打造新东耐火一流优质产品，

我们将一如继往-永不懈怠!

定碳仪 Carbon Analysis

X荧光光谱仪 S4EXPLORER



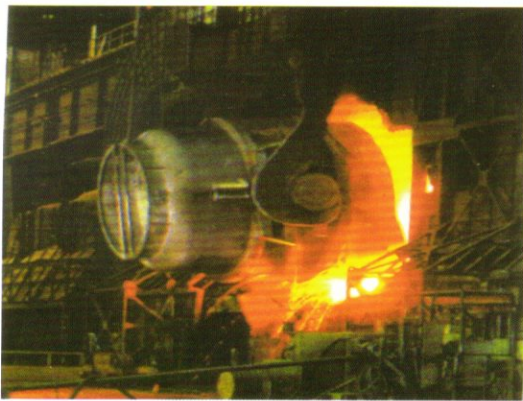
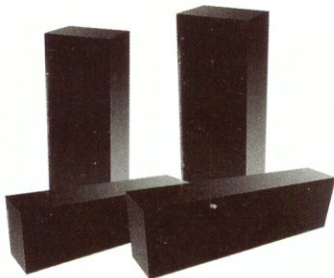

- 炉帽 cone
PG-10MS
PG-15CN
PG-18CN
PG-20CN
- 炉墙 Side Wall
PG-15BL
PG-18BL
PG-18BLS
PG-25BL
- 炉底 Bottom
PG-18BL
PG-18BLS
PG-25BL

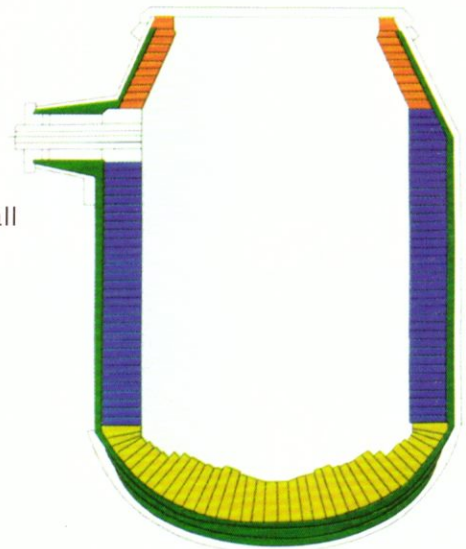

转炉用镁碳砖 MgO-C Bricks for Converter(1)

	PG-10MS	PG-15CN	PG-18CN	PG-20CN
MgO (%)	80	78	75	75
C (%)	9	14	16	17
Apparent Porosity(%)	5	4	5	5
Bulk Density	2.80	2.95	2.80	2.85
Cold Crushing Strength(Mpa)	35	35	35	35
Applications	Cone			

转炉用镁碳砖 MgO-C Bricks for Converter(2)

	PG-15BL	PG-18BL	PG-18BLS	PG-25BL
MgO (%)	78	78	78	72
C (%)	14	14	17	23
Apparent Porosity(%)	4	3	3	3
Bulk Density	2.95	2.92	2.90	2.80
Cold Crushing Strength(Mpa)	35	35	40	35
Applications	Barrel, Bottom			

每个牌号都有其系列产品，可以满足顾客各种需要

There is a series of bricks products for a single grade of bricks to meet the consumer's demands

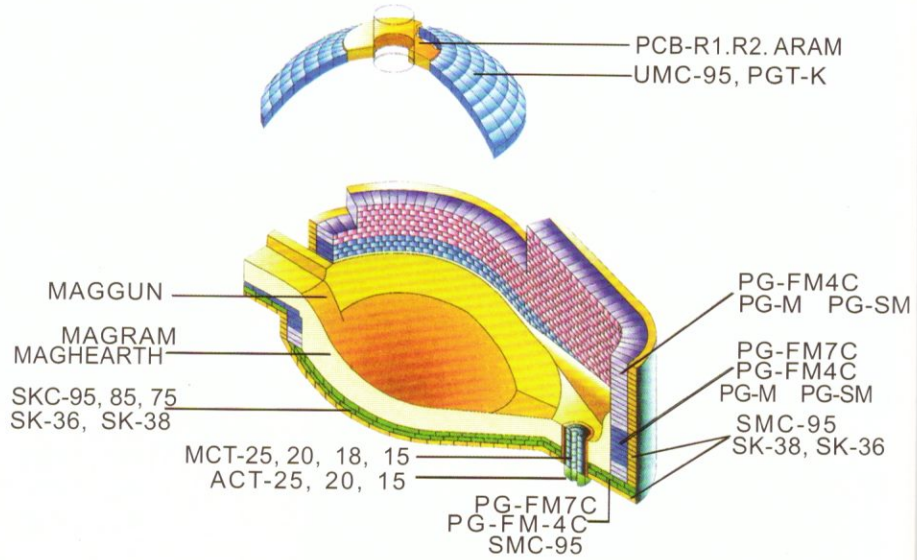
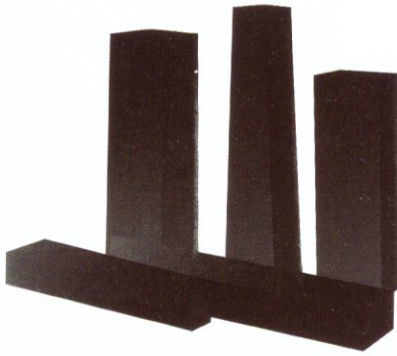

电炉用镁碳砖 MgO-C Bricks for EAF

	PG-FM7C	PG-FM7CS	PG-FM4C	PG-FM4CM
MgO (%)	78	78	75	75
C (%)	14	15	14	14
Apparent Porosity(%)	4	3	3	4
Bulk Density	2.95	2.98	2.95	2.90
Cold Crushing Strength(Mpa)	35	40	35	35
Applications	Hot Spot Slag Line		Metal Line	

每个牌号都有其系列产品，可以满足顾客各种需要

There is a serious of bricks products for a single grade of bricks to meet the consumer's demands

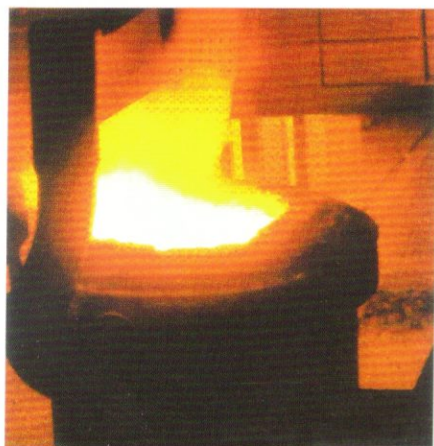

- 渣线 Slag line
PG-BT15
PG-BT15S
PG-BT15SL
- 包壁 Ladle Wall
AMG-W1
AMG-W2
AMG-WH
PG-BT15M
- 包底 Ladle Bottom
AMG-B1
AMG-B2

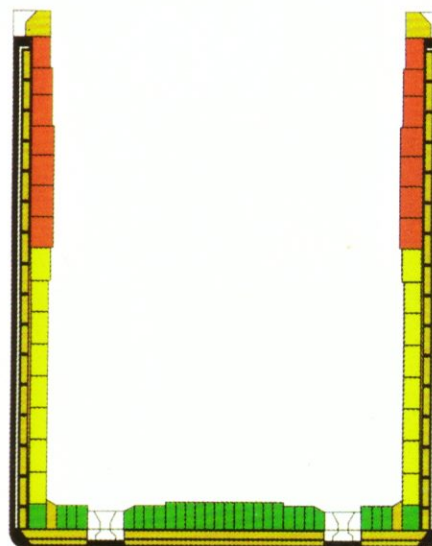

钢包用镁碳砖 Magnesia-Carbon Bricks For Ladle

	PG-BT15	PG-BT15S	PG-BT15SL	PG-BT15M
MgO (%)	75	77	78	75
C (%)	14	14	14	14
Apparent Porosity(%)	4	3	3	4
Bulk Density	2.95	3.00	3.02	2.95
Cold Crushing Strength(Mpa)	35	40	40	40
Applications	Slag Line	Slag Line	Slag Line	Metal Line

每个牌号都有其系列产品，可以满足顾客各种需要

There is a serious of bricks products for a single grade of bricks to meet the consumer's demands

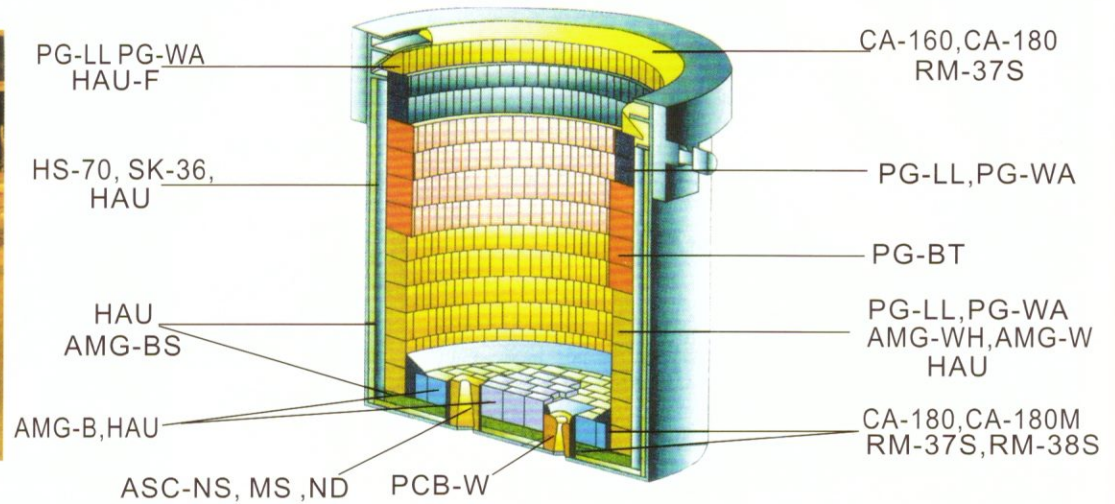
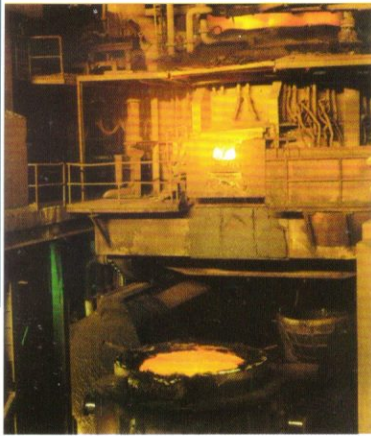

钢包用铝镁碳砖 Alumina-Magnesia-Carbon Bricks For Ladle

	AMG-WH	AMG-W1	AMG-W2	AMG-B1	AMG-B2
MgO (%)	40	20	10	12	15
Al ₂ O ₃ (%)	40	60	70	70	64
C (%)	10	10	8	8	10
Apparent Porosity(%)	7	7	8	8	7
Bulk Density	3.05	3.05	3.05	3.05	3.00
Cold Crushing Strength(Mpa)	40	40	40	40	35
Applications	Metal Line			Bottom	

每个牌号都有其系列产品，可以满足顾客各种需要

There is a series of bricks products for a single grade of bricks to meet the consumer's demands

TYPE	A	B	C	D	V(cm ³)
LW50	230	50	114	114	1.311
LW51	230	50	114	107	1.271
LW61	230	65	114	105	1.637
LW62	230	65	114	95	1.562
LW80	230	80	80	80	1.472
LW81	230	80	80	70	1.380
LW82	230	80	80	60	1.288
LW90	230	90	80	80	1.656
LW91	230	90	80	70	1.553
LW92	230	90	80	60	1.449
LW95	230	90	80	76	1.615
LW110	230	114	80	80	2.098
LW111	230	114	80	70	1.967
LW112	230	114	80	60	1.835
LW150	230	150	80	80	2.760
LW151	230	150	80	70	2.588
LW152	230	150	80	60	2.415
LW180	230	180	80	80	3.312
LW181	230	180	80	70	3.105
LW182	230	180	80	60	2.898
LW200	230	200	80	80	3.680
LW201	230	200	80	70	3.450
LW202	230	200	80	60	3.220
LW210	230	210	80	80	3.864
LW211	230	210	80	70	3.623
LW212	230	210	80	60	3.381
LW230	230	230	80	80	4.232
LW231	230	230	80	70	3.968
LW232	230	230	80	60	3.703
LW250	230	250	80	80	4.600
LW251	230	250	80	70	4.313
LW252	230	250	80	60	4.025
LW280	230	280	80	80	5.152
LW281	230	280	80	70	4.830
LW282	230	280	80	60	4.508
LW300	230	300	80	80	5.520

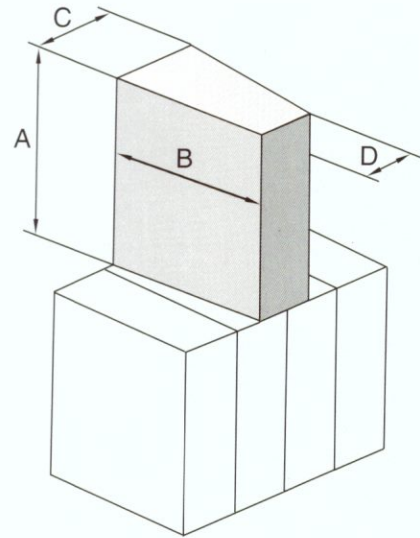
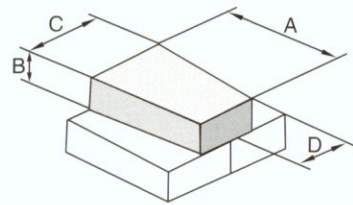

TYPE	A	B	C	D	V(cm ³)
K4	350	114	105	65	2.491
K5	350	114	85	65	2.264
K6	350	114	65	65	2.036
M281	280	114	105	65	1.993
M282	280	114	85	65	1.811
M281-1	280	114	105	40	1.226
M281-2	280	114	85	40	1.114
M331	330	130	120	65	2.681
M332	330	130	95	65	2.413
M331-4	330	85	75	65	1.716
M331-5	330	130	95	40	1.485
M230	350	200	200	65	4.550
M440	440	150	150	65	4.290
K4-32	350	114	105	32	1.226
K5-1/2	350	54	39.5	65	1.064
K6-1/2	350	54	29.5	65	950
1.5J-32	350	114	114	32	1.277
1.5J	350	114	114	65	2.594
K61/2-1	400	54	25.8	65	1.037
K51/2-1	400	54	34.5	65	1.151
K6-1	400	114	55	65	2.197
K5-1	400	114	75	65	2.457
K4-1	400	114	90	65	2.652
1.7J	400	114	114	65	2.964

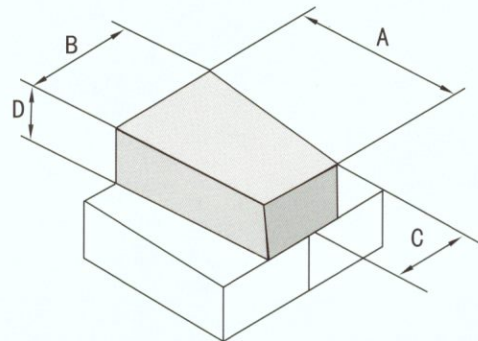

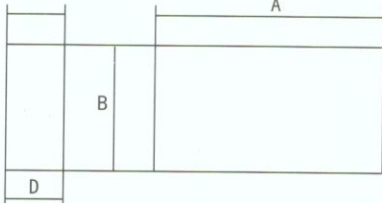
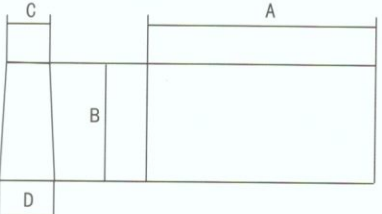
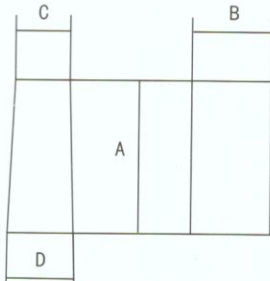
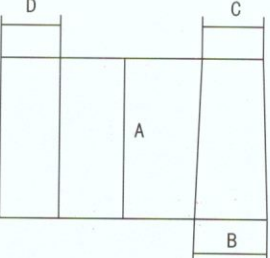
MARK		A	B	C	D	JIS	Shape
STD		230	114	65	65		
KTYPE	K1	230	114	65	59	Y-1	
	K2	230	114	65	50	Y-2	
	K3	230	114	64	32	Y-3	
JTYPE	J1	230	114	65	55	T-1	
	J2	230	114	65	45	T-2	
	J3	230	114	65	35	T-3	
STYPE	S1	230	114	105	65	B-1	
	S2	230	114	85	65	B-2	
	S3	230	114	65	65	B-3	

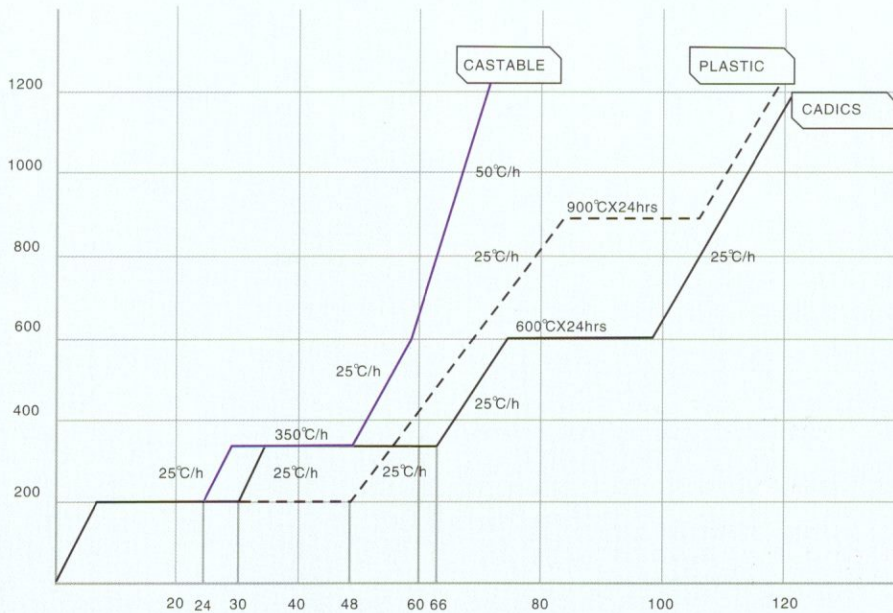
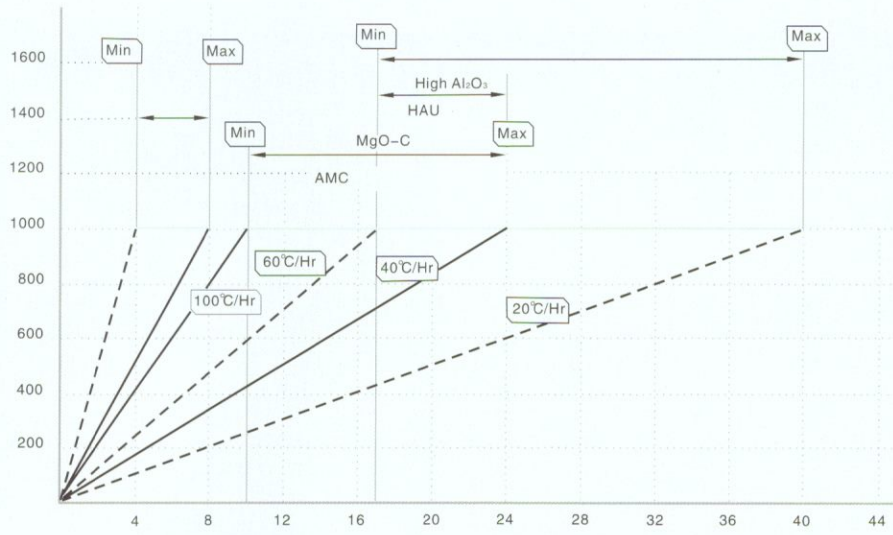

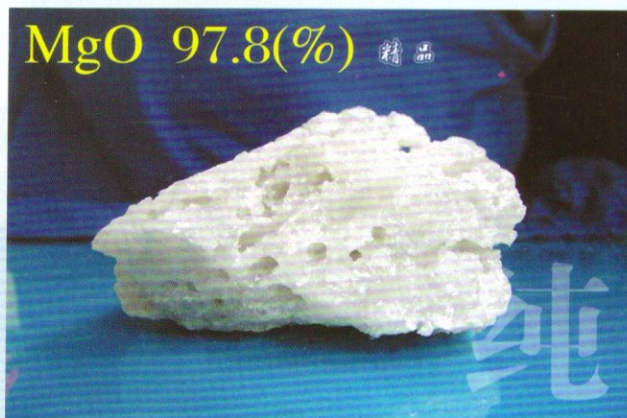
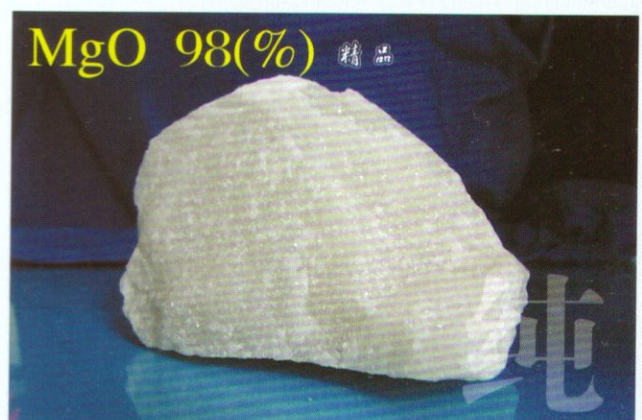
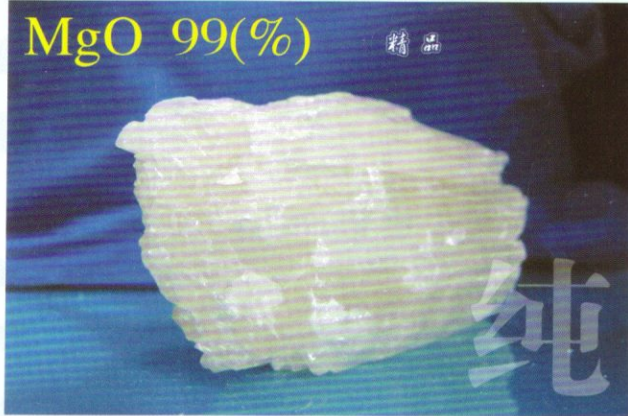



	MgO ≥%	SiO ₂ ≤%	Fe ₂ O ₃ ≤%	CaO ≥%	LOI 灼减≤%	B.D. 体密 G/CM ³	Colors 颜色
1	99	0.18 0.20	0.18 0.20	0.40 0.50	0.10 0.08	3.52 3.50	白 WHITE
2	98.5	0.28 0.30	0.28 0.30	0.70 0.80	0.10 0.08	3.51 3.50	白 WHITE
3	98.2	0.35 0.40	0.35 0.40	0.90 0.90	0.10 0.10	3.51 3.50	白 WHITE
4	98	0.40 0.45	0.40 0.45	1.10 1.10	0.10 0.10	3.50 3.48	白 WHITE
5	97.5	0.50 0.60	0.50 0.60	1.40 1.50	0.15 0.15	3.50 3.48	白 WHITE
6	97	0.60 0.65	0.60 0.65	1.50 1.60	0.15 0.20	3.50 3.48	棕 Brown
7	96.5	0.65 0.80	0.65 0.80	1.80 1.80	0.15 0.20	3.45 3.41	棕 Brown



“创新” “高效” “务实” “拼搏” “和谐” “双赢”

- 创新是新东耐火的发展基石;
- 高效是新东耐火的发展目标;
- 务实是新东耐火的发展动力;
- 拼搏是新东耐火的发展精神;
- 和谐是新东耐火的发展理念;
- 双赢是新东耐火的发展宗旨;

——新东耐火愿与您携手未来，共创辉煌！





营口新东耐火材料有限公司

YINGKOU NEW EAST REFRATORIES CO.,LTD.

.....

地址：营口市南楼经济开发区观马山工业园区

Add : Guanmashan Industrial Park,Nanlou Economic Development Zone,Yingkou City

电话：0417-5887007 5887000

Tel : +86-417-5887007 5887000

传真：0417-5887900

Fax : +86-417-5887900

邮编：115103

P.C : 115103

网址：www.YKXD.com.cn

Http: www.YKXD.com.cn